

Electronic thermostats for immersion heaters

Enclosure	Type	Operation	Contact	Measurement	Ranges °C	Models
IP66,IK10	Control	Electronic	SPNC	Immersion heater		YF82NC
Material						
PA66 & PC						

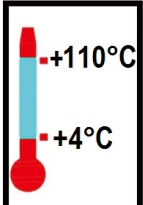
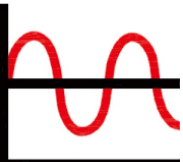
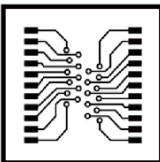
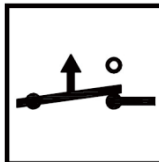
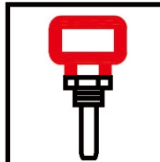
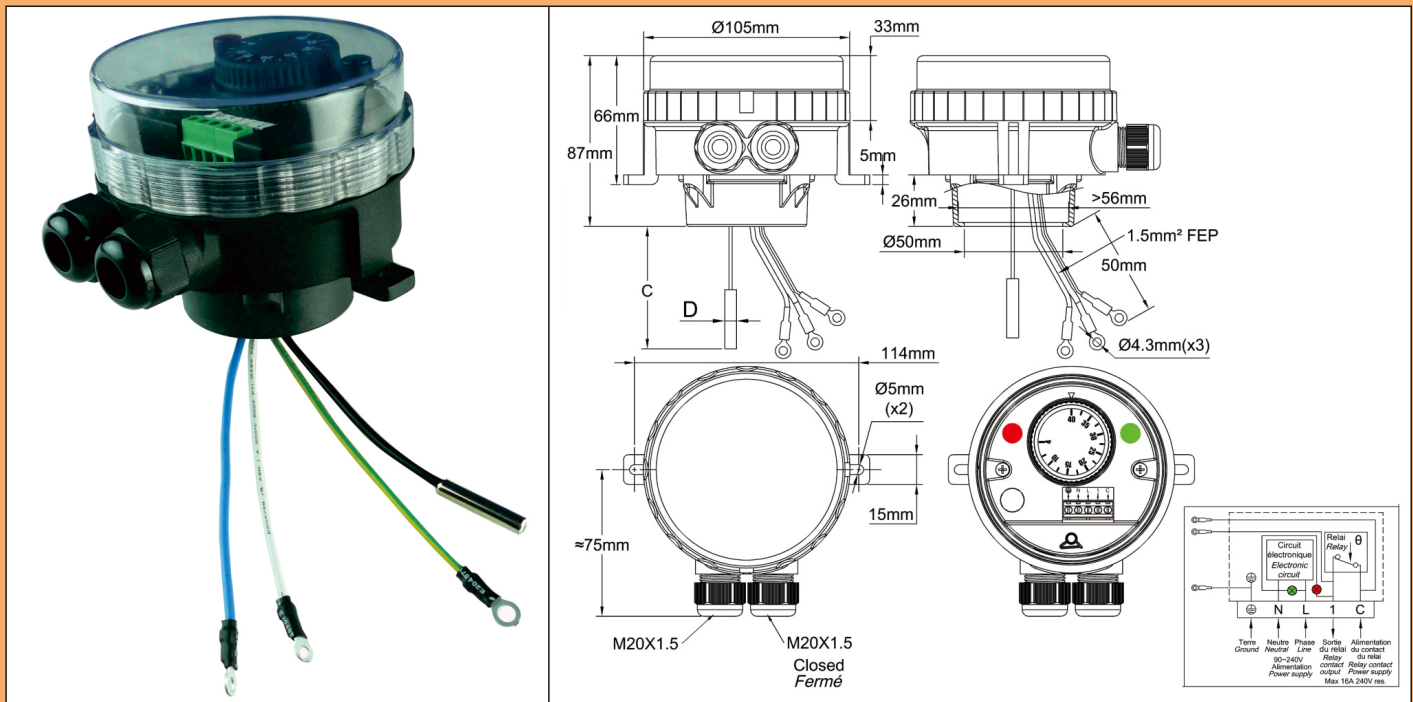

Applications

-Equipment requesting a very strong resistance to water ingress. The transparent cover allows to visualize the set point and the 2 pilot lights

Fully wired sub assembly for direct mounting on immersion heater elements, 1 1/2" or M45x2 with double thread or rotation ring. Applications in usual industrial applications and environments, non-hazardous areas.

-Very small differential

Housing: Protection class IP 66 upon EN 60529 (waterproof spray water under high pressure and sea splashes, totally dust tight). Body in black PA66, fiber glass reinforced. The transparent polycarbonate cover can be unscrewed by hand, but it is also possible to use a hook spanner. A removable adapter is screwed at the bottom of the enclosure. It fits the usual immersion heater fittings. .Mechanical impact resistance : IK10. High UV resistance..

Set point adjustment: By °C printed knob. All types have an adjustable rotation limit system located inside the knob that allows reducing the set point adjustment span. °F printed knobs available in option

Operation: Microprocessor electronic thermostat, on-off action .

Set point adjustment ranges: 4-40°C (40-105°F); 30-90°C (85-195°F); 30-110°C (85-230°F).

Differential: Differential is preset at the minimum value, but can be increased with a potentiometer located under the set point adjustment knob.

Sensing element: The 5x 30mm NTC sensor (10KOhms @25°C) goes out by the bottom of the enclosure to fit in the immersion heater pocket.

Pilot lights: One pilot light visualizes the thermostat contact output position. The other visualizes the power supply input. Phase and line 230V power supply is mandatory for these pilot lights.

Cable input and output: Two M20 cable glands, built-in black PA66. One of them is closed.

Electrical connections: Inside, on screw terminal connection block.

Earthing: Internal screw terminal and 1.5mm² FEP insulated wire with round hole terminals for the immersion heater.

Mounting: By the immersion heater thread or by 2 legs with holes for screws dia. 4 to 5 mm, 114 mm distance

Identification: Identification label on backside.

Contact: SPNC. 16A (2.6), 250VAC. Contact open on temperature rise

Electrical life: >100.000 cycles.

Minimum storage temperature: -35°C (-30°F)

Maximum ambient temperature: 60°C (140°F)

For more technical information ask 2PE2N6 thermostat technical data sheet